

Reinvention scheme bench set
Technical drawings and specifications



REINVENTION FURNITURE

PART 1 – GENERAL

1.01 SUMMARY

- A. The scope of work includes the fabrication and delivery of freestanding “weather-resistant” classroom furniture:
 - 1. Double Bench
 - 2. Double Desk
- B. Work includes, but is not limited to the following:
 - 1. Labor, equipment, and material to fabricate freestanding classroom furniture.
 - 2. Labor, equipment, and material to protect and transport freestanding classroom furniture, and/or its components, from the factory/workshop to the final installation locations.
 - 3. Testing and quality control of classroom furniture and/or its components.
- C. In the context of this specification, “weather-resistant” classroom furniture refers to the ability of the furniture to withstand limited exterior conditions such as humidity and moisture. The furniture is intended for use in indoor, unconditioned spaces, or semi-outdoor spaces, such as verandas, patios, etc.

1.02 REFERENCES

- A. Reference Standards and Regulatory Requirements:
 - 1. Where there are in existence national standards, regional standards, European Standard (EN), European Standard adopted International Organization for Standardization (EN ISO), or Normes Française (NF) Standards applicable to this type of product and work, the recommendations and requirements of such Standards shall be considered minimum standards for the installation described, and must be complied with.
 - 2. Reference to a Standard or Code shall be deemed to include all other Standards and Codes referred to in the specified Standard or Code.
 - 3. Nothing herein shall relieve Trade Contractor of its responsibility to provide a higher standard than the relevant Code or Standard, where that is required in order to comply with other parts of the Specifications.

1.03 SUSTAINABILITY REQUIREMENTS

- A. Specific project goals of work include: use of recycled-content materials, use of recyclable materials, use of locally-manufactured materials, use of woods and plywood that are certified as renewable, use of low VOC-emitting materials, construction waste management and recycling, and the

implementation of a construction indoor air quality management plan.

- B. For wood, and plywood, certification of origin from a sustainable source shall be provided.
- C. Furniture Contractor shall provide UNICEF representative with sustainability criteria for all component parts of classroom furniture prior to fabrication.

1.04 QUALITY ASSURANCE

- A. The following methods of assuring quality are required by UNICEF:
 - 1. Furniture Contractor shall fabricate and assemble one piece of each type of furniture prior to production. This “Test Unit” shall be used to verify drilled hole locations, assure alignments are consistent with the Design Drawings and Technical Specifications and perform all Quality Assurance Tests identified in Section 2.01 on each test unit. All tests shall be observed by the UNICEF representative. Apply all sample finishes to test units in areas of at least 150mm x 150mm and apply each of the finish colors to an entire steel leg or leg support component. The assembled Test Units and sample finishes shall be evaluated for compliance with the Design Drawings and Technical Specifications and approved by the UNICEF representative prior to commencement of production.
 - 2. Conduct a detailed inspection and testing of one piece of each type of fully assembled furniture during production in the fabricator’s workshop in the presence of the UNICEF representative for every 100 units or less produced using all Quality Assurance tests identified in Section 2.01.
 - 3. Conduct a detailed inspection and testing of one piece of each type of furniture taken at random once assembled and installed in a school for every 100 units or less assembled using Quality Assurance tests identified in Section 2.01, tests F.3 and F.4.
- B. The regularity of these inspections is to be determined by individual contract with UNICEF, but is recommended to be a minimum of once per order.

1.05 WARRANTY

- A. Furniture Contractor shall submit a written warranty agreeing to repair or replace units or components which fail in materials or workmanship within the specified warranty period. Warranty period is one year after the date of furniture delivery/installation.
- B. Furniture Contractor shall provide a written guarantee of availability of components compatible with the original

furniture construction for a period of not less than one year after the date of furniture delivery/installation.

PART 2 - TESTING

2.01 QUALITY ASSURANCE TESTS

- A. General
 - 1. Refer to Section 1.04 for description of testing of Test Units, assembled units during production in the fabricator’s workshop, and randomly selected assembled furniture once it is assembled in a school.
 - 2. Test F, listed below, shall be performed on assembled furniture pieces both at the production workshop and at the school. A UNICEF representative shall be present for testing/test results.
- B. Bend test on metal finishes
 - 1. Test a finished metal piece by bending it over a 12 mm mandrel. If the finish cracks, it is not acceptable.
- C. Scratch test on metal finishes
 - 1. Pull a rough-edged stone weighing 3 kg over a finished metal piece. If the finish is scratched, it is not acceptable.
- D. Adhesion test on metal finishes
 - 1. Firmly apply a 100 mm piece of clear-self-adhesive tape on finished metal piece and rip it off. If the finish damaged, it is not acceptable.
- E. Resistance to marking by liquids
 - 1. Place a sponge (50x75x25 mm) soaked with water on top of the finished surface of a desk and bench for 4 days. The sponge shall be kept wet for the duration of the test. At the end of the test, the surface shall be dried. If there is damage to the finish, it is not acceptable.
- F. Loading test
 - 1. Drop a 60 kg weight from 100 mm above onto the desk and chair/bench surfaces 30 times. If there is damage to the furniture, it is not acceptable.
 - 2. Place 25 kg weights at 3 of the 4 corners of the desk and chair/bench. If the furniture does not remain stable, it is not acceptable.
 - 3. Place the bottom of the side legs against a fixed edge along the floor. Apply moderate pressure from the opposite side by pushing against the seat, bench or desk top. If the furniture racks, it is not acceptable.

PART 3 - MATERIALS

3.01 ACCEPTABLE CONSTRUCTION OPTIONS

- A. Laminated plywood with steel tube leg assembly, or
- B. Laminboard with steel tube leg assembly, or

- C. Plastic laminate on laminated plywood or composite wood with steel tube leg assembly.

3.02 Materials

A. General

1. Provide all materials for desk tops/shelves and bench as described in the Design Drawings.
2. All wood shall be obtained from responsibly managed forest and/or plantations in accordance with local laws and regulations governing forest management.
3. All wood shall be kiln dried to 5% moisture content.
4. All wood shall be Top Grade, select local species and free from cat's eyes, bird's eyes, burls, curls, or cross grains.
5. All wood for the same piece of furniture shall have consistent color and grain pattern. Grain direction should run parallel with the long direction of component piece.
6. Adhesives shall be waterproof and must not discolor any materials being used.
7. Only BR (boil resistant) and WBP (waterproof and boilproof) adhesives shall be used. Examples include phenol formaldehyde and epoxy adhesives.

B. Sheet Material

1. Plywood
 - a. The grains of each ply shall be at right angles to the next (crossbanding). Sitting and desktop writing surfaces shall be grade A plywood or better so that knots are minimized.
2. Laminboard
 - a. Core of wood strips or veneers between outer veneers with their grain direction at right angles to the grain of the core.
 - b. Cores shall be 1.5 mm to 7 mm max wide strips or veneers, glued together face to face.
3. Plastic Laminated Sheet Material
 - a. Only high pressure plastic laminate (HPL) shall be used; low pressure laminates (LPL) are not acceptable.
 - b. Adhere plastic laminate to plywood, laminboard or dense particle board.
 - c. Top of desk, top of desk shelf, chair/bench seat and chair/bench back (both sides) surfaces shall be fully covered with plastic laminate.

C. Steel Products

1. Use only materials which are smooth and free of surface blemishes including pitting, seam marks, roller marks, rolled trade names and roughness.
2. Steel Sections
 - a. Metric Round Steel Pipe

- i. Provide leg assembly and cross brace in dimensions described in the Design Drawings (Reinvention Furniture).
- ii. Wall of steel tube section shall be at least 2 mm thick. The diameter of steel tube sections shall be no less than 25mm for structural components.

b. Steel Wire

- i. Provide steel wire bent to the shape of a bag hook in dimensions described in the Design Drawings.
- ii. Use bent steel wire that is a minimum of 5mm thick.

D. Fasteners and Accessories

1. Metric Pan Head Machine Screw
 - a. Zinc-Plated Steel
 - b. Refer to Design Drawings for sizes and dimensions
2. Metric Carriage Bolt
 - a. Zinc Low Carbon Steel
 - b. Refer to Design Drawings for sizes.
3. Metric Self Locking Nut with Nylon Insert
 - a. Steel Zinc-Plated
 - b. Refer to Design Drawings for sizes.
4. Hard plastic Saddle Foot with Peg
 - a. Refer to Design Drawings for product and sizes
 - b. This piece is integral to the performance of the furniture piece. If furniture Contractor is not able to acquire the piece, an alternate shall be proposed. If an acceptable alternative is not provided, the UNICEF representative may elect to have no saddle feet provided the furniture is stable without them.

PART 4 – TECHNICAL SPECIFICATIONS

4.01 DESIGN

- A. Sizes: Refer to Design Drawings for small, medium and large furniture descriptions and all dimensions and component part configurations.
- B. Colors
1. Steel components of furniture shall be painted in four different finish colors in equal numbers for each size of furniture provided.
 2. Steel components for each desk, bench and chair shall be a single color. They shall also be the same for each desk / bench set.
 3. Colors are:
 - a. UNICEF Blue – Pantone Process Cyan C
 - b. Orange – Pantone Orange 021 C
 - c. Light Green – Pantone 376 C

- d. Chartreuse – Pantone 3965C

4. Refer to Pantone web site to see image of colors: <http://www.pantone.com/pages/pantone/colorfinder.aspx>
5. Samples of color ranges shall be submitted to the UNICEF representative for evaluation and approval before fabrication.
6. Certain areas of the furniture shall be painted with chalkboard paint, refer to Design Drawings and Section 4.03 Finishes.

4.02 FABRICATION

A. Sheet Material and Wood

1. Cut sheet material and leg pieces to size using table and band saws to achieve straight and square cuts.
2. Rout edges to achieve rounded profiles as described in the Design Drawings.
3. Ease exposed wood edges that are not otherwise routed.
4. Drill holes to receive bolts as described in the Design Drawings.
5. Avoid cutting and drilling techniques that splinter or fray the edges of material. Cuts and drilled holes shall be clean and precise.

B. Steel

1. Cut Metric Round Steel Pipe to size using a metal band saw to achieve straight and square cuts as described in the Design Drawings.
2. Cut steel wire to size using a metal band saw to achieve straight and square cuts and grind ends round as described in the Design Drawings.

C. Steel Bending

1. Use a pneumatic pipe bender or a custom bending jig to bend Metric Round Square Pipe.
2. Pipe bends shall be square to the leg assembly and consistent in radii described in the Design Drawings.

D. Steel Preparation and Welding

1. Welds exposed to view shall be ground flush and dressed smooth to match finish of adjoining surfaces; undercut metal edges where welds are required to be flush.
2. Welds shall be continuous.
3. All welds on or behind surfaces which will be exposed to view shall be done so as to prevent distortion of finished surface.
4. All exposed edges shall be slightly eased to eliminate sharp edges.
5. TIG (Argon-arc) welding is recommended. Any commercial welding is acceptable. Add filler metal as required. Weld size shall be equal to the thickness of the

steel being joined. Electrodes for standard grade steel A36 shall be AWS 5.1, Class E70XX.

4.03 FINISHES

A. Metals

1. All metal parts shall receive powder coat painting. Substrate shall be free of grease, oil, dirt, fingerprints and drawing compounds.
2. For regions where powder coating is not available, hand painting metals shall be acceptable. Thoroughly cleaned metal shall receive one coat of red-oxide primer and 3 coats of enamel paint. Each coat of enamel paint shall be lightly diluted with thinner (2% max), and after the first and second coat of enamel paint has dried properly, metal shall be lightly sanded with flint paper (grade 200 and above) to remove bubbles and sharp points. The final coat shall give a smooth, even, and hard topcoat. Paint coats shall be fully dried prior to application of next coat.
3. Enamel shall be a non-chipping type.
4. Refer to colors in Section 4.01 of this design specification.

B. Wood

1. Wood shall be thoroughly sanded in the direction of wood grain using three gradations of sandpaper to produce a smooth surface.
2. All wood shall be finished with 3 coats of lacquer with a light sanding between coats 1 and 2.
3. All wood surfaces to receive lacquer shall be thoroughly cleaned and free of dirt, oil, grease, moisture, or other foreign matter prior to painting.
4. All wood finishes shall be non-toxic.
5. Chalkboard paint
 - a. Two coats of acrylic paint with durable finish shall be used.
 - b. Apply to a wood surface with primer designed to provide block between wood and finish paint.

PART 5 - MISCELLANEOUS

5.01 PACKAGING

A. Internal packaging components

1. Furniture component parts to be shipped in flat corrugated cardboard containers and packed in such a way to avoid crushing, scratches and abrasions during shipping.

B. Furniture contractor shall be responsible for protection of furniture pieces during transportation.

5.02 ASSEMBLY/REPAIR KIT

- A. Provide one adjustable bolt wrench that fits the specified hex nut, one flathead screwdriver sized for the specified screws and a rubber mallet.
- B. Provide up to two screws and bolt/nut assemblies in each size for each desk and bench unit provided by the Furniture Contractor.
- C. Provide four additional feet for each individual furniture piece.
- D. Assembly/Repair Kit: Provide two kits for orders between 1 and 200 desk and chair/bench units and an additional kit for each additional 1 to 100 unit increment.

5.03 TRAINING

- A. Furniture Contractor shall provide an information session to school personnel on assembling and maintaining the furniture. This is required at each school where classroom furniture is installed.
- B. Certification letter from Furniture Contractor stating successful completion of school personnel training, signed by both the Furniture Contractor and school representative.

END

DESK COMPONENTS



SCHEDULE: DESK

ITEM	QTY	DESCRIPTION	NOTES	PG#
A	2	FRAME	25 mm AND 19 mm DIAMETER STEEL PIPES, POWDER COATED/PAINTED GREEN, PANTONE 376 C	AI-2
B	1	DESKTOP	19 mm THICK SHEET MATERIAL	AI-5
C	1	SHELF	19 mm THICK SHEET MATERIAL	AI-7
D	1	MODESTY PANEL	19 mm THICK SHEET MATERIAL	AI-6
E	1	SHELF DIVIDER	19 mm THICK SHEET MATERIAL	AI-8
F1	12	CARRIAGE BOLT	M8 X 1.25 mm THREAD, X 55 mm LENGTH, ZINC PLATED	I-3
F2	12	HEX LOCKNUT WITH NYLON INSERT	M8 X 1.25, ZINC PLATED	I-3
F3	4	WOOD SCREW	M5, X 14 mm LENGTH, ZINC PLATED, FLAT HEAD	I-3
F4	12	WASHERS	ZINC PLATED	I-3
G2	2	90 DEGREE CLIP	19 mm X 19 mm, 2 HOLES, ZINC PLATED	I-3
H	4	SADDLE FOOT	HARD PLASTIC SADDLE FOOT, 25 mm INSIDE DIAMETER	I-3

BENCH COMPONENTS

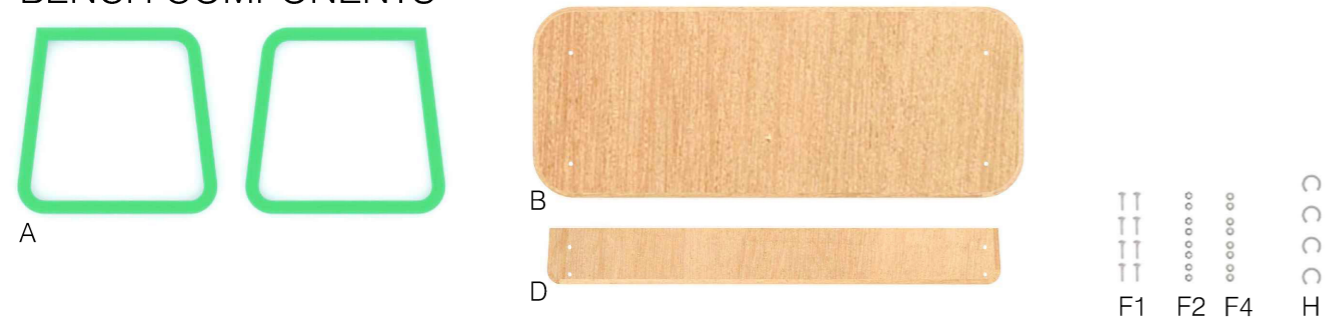

SCHEDULE: BENCH

ITEM	QTY	DESCRIPTION	NOTES	PG#
A	2	FRAME	25 mm DIAMETER STEEL PIPES, POWDER COATED/PAINTED GREEN, PANTONE 376 C	AI-12
B	1	SEAT	19 mm THICK SHEET MATERIAL	AI-3
D	1	KNEE PANEL	19 mm THICK SHEET MATERIAL	AI-4
F1	8	CARRIAGE BOLT	M8 X 1.25 mm THREAD, X 55 mm LENGTH, ZINC PLATED	I-3
F2	8	HEX LOCKNUT WITH NYLON INSERT	M8 X 1.25, ZINC PLATED	I-3
F4	8	WASHERS	ZINC PLATED	I-3
H	4	SADDLE FOOT	HARD PLASTIC SADDLE FOOT, 25 mm INSIDE DIAMETER	I-3

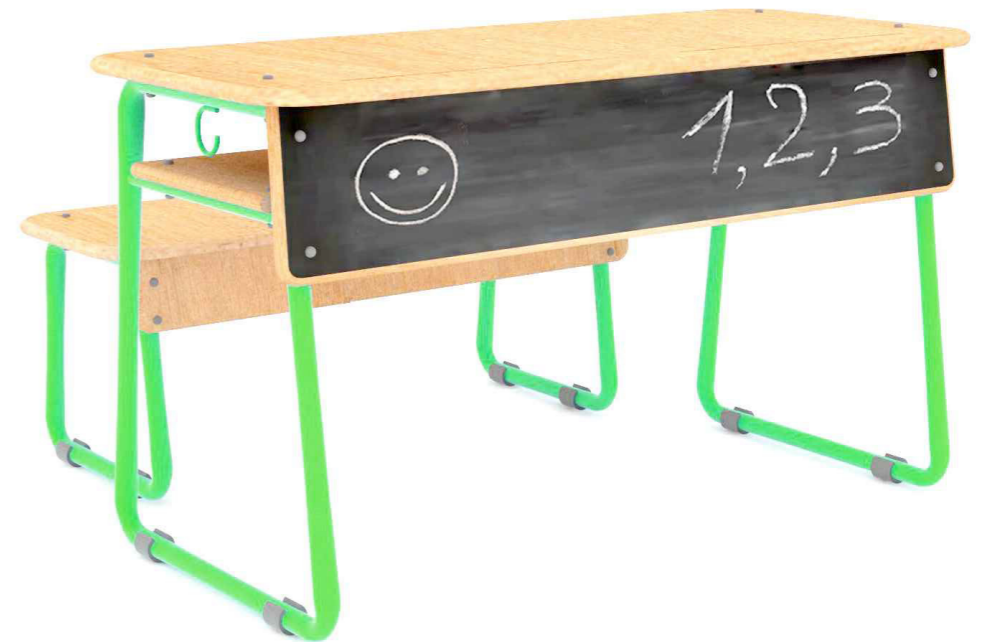
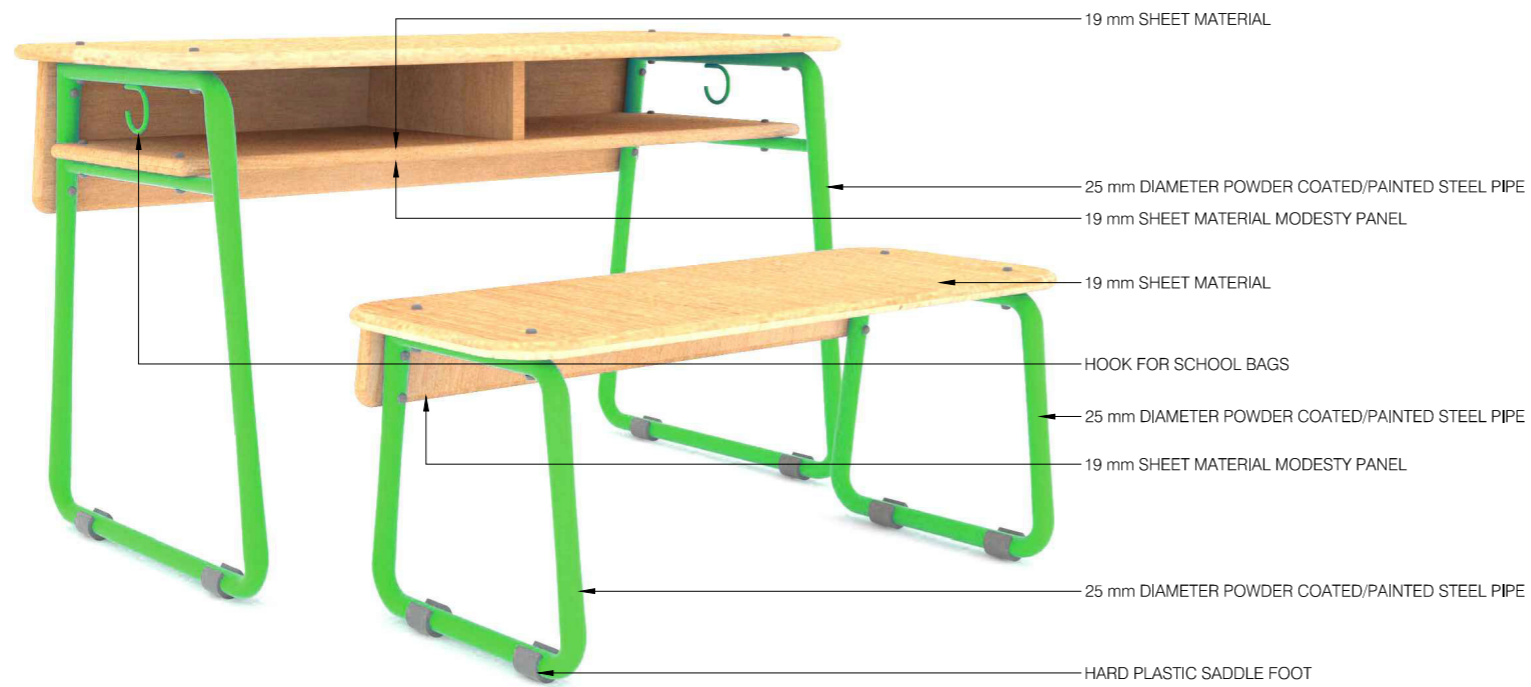

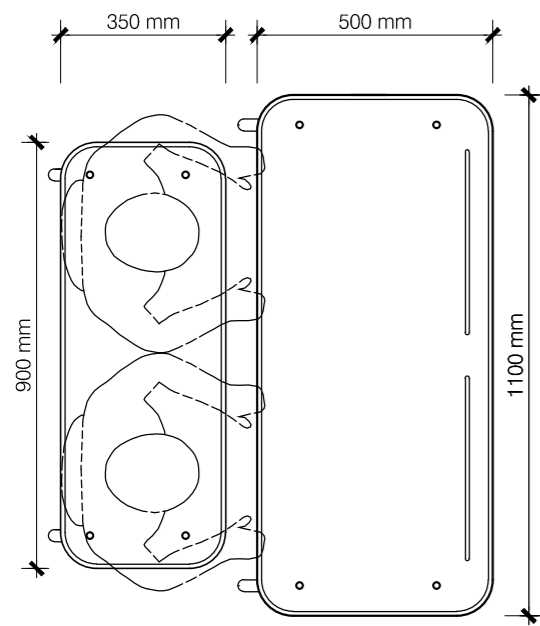
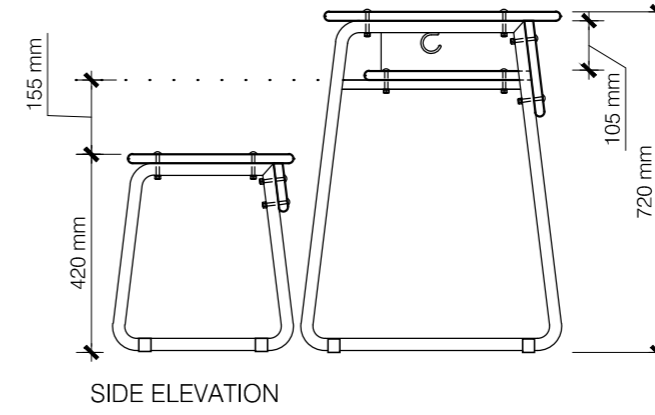
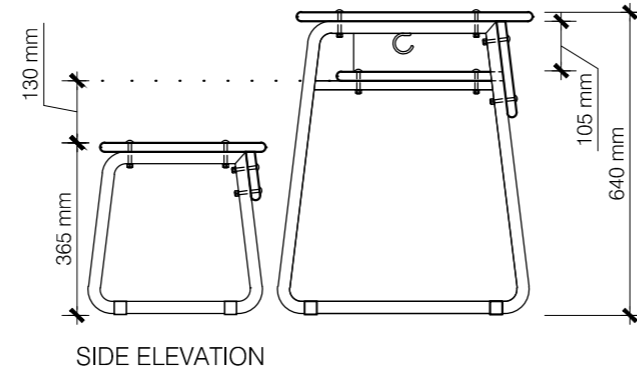
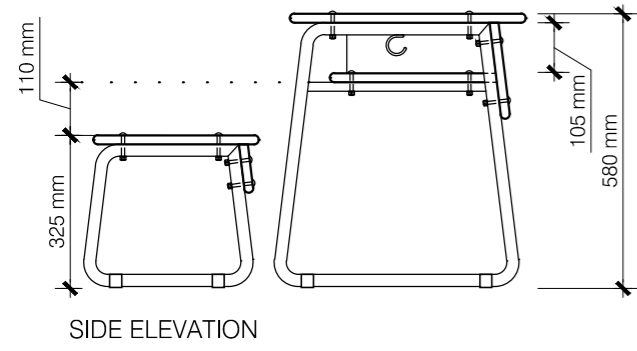

01 SMALL (S) PLAN
1:16 SCALE

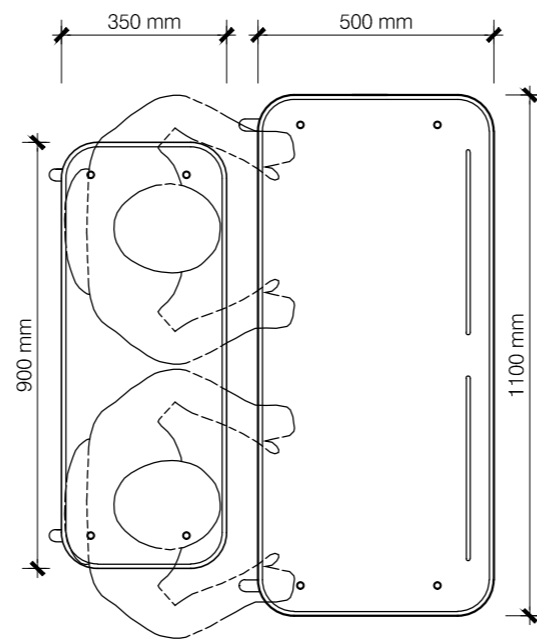

02 MEDIUM (M) PLAN
1:16 SCALE

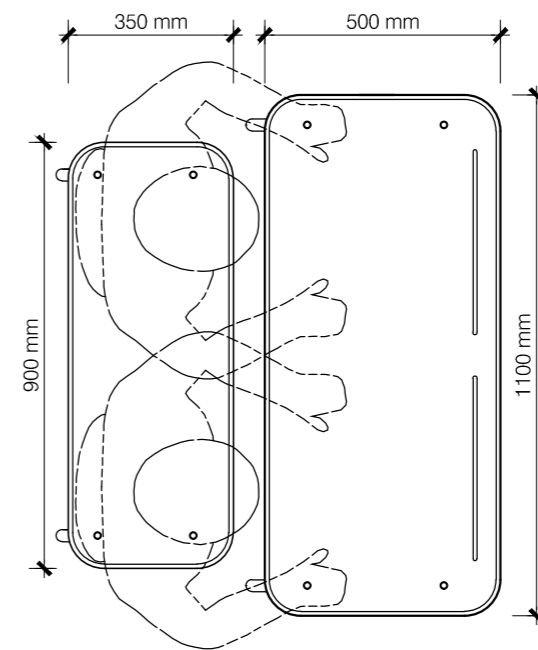

03 LARGE (L) PLAN
1:16 SCALE

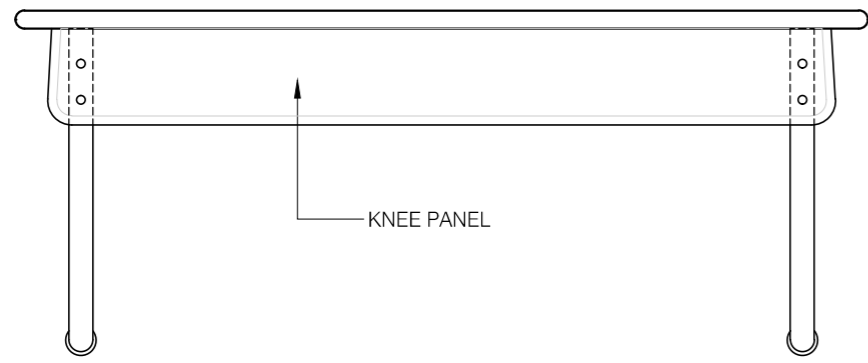

01 BENCH FRONT ELEVATION
1:8 SCALE

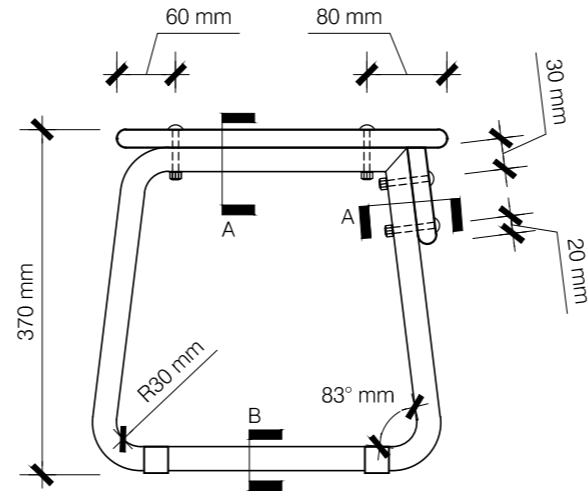

02 BENCH SIDE ELEVATION
1:8 SCALE



03 BENCH REAR ELEVATION
1:8 SCALE

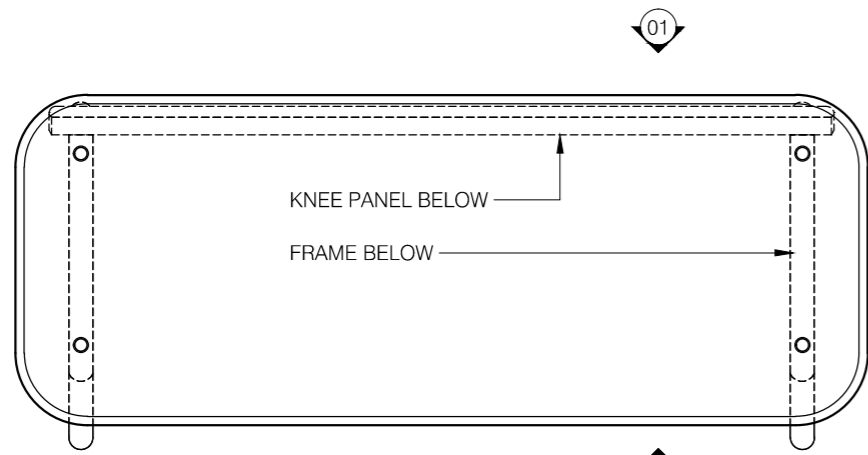

04 BENCH PLAN
1:8 SCALE

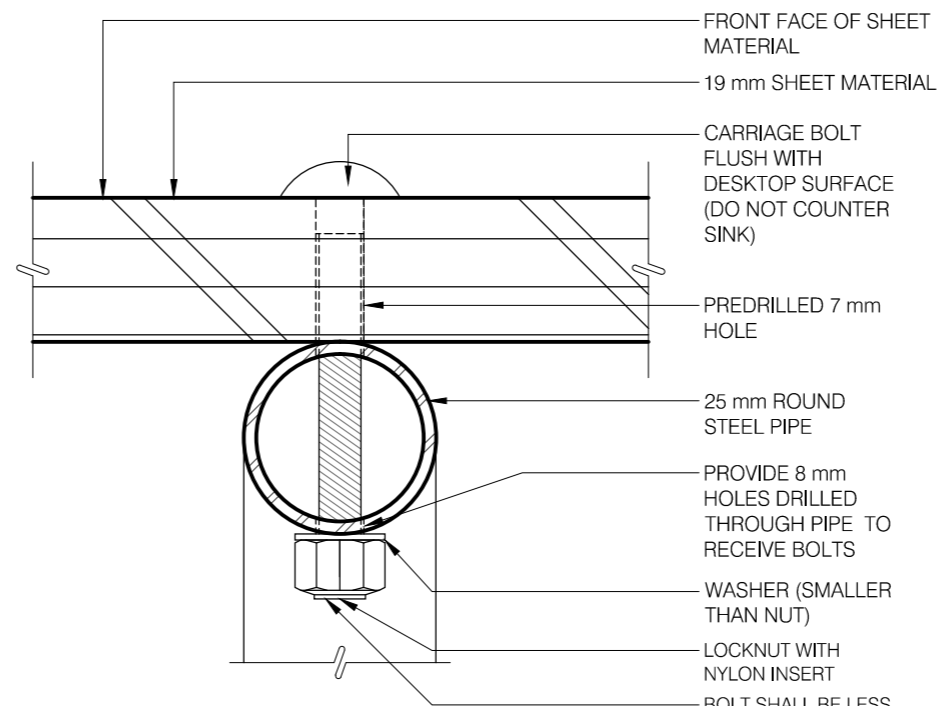

A SECTION DETAIL
1:1 SCALE

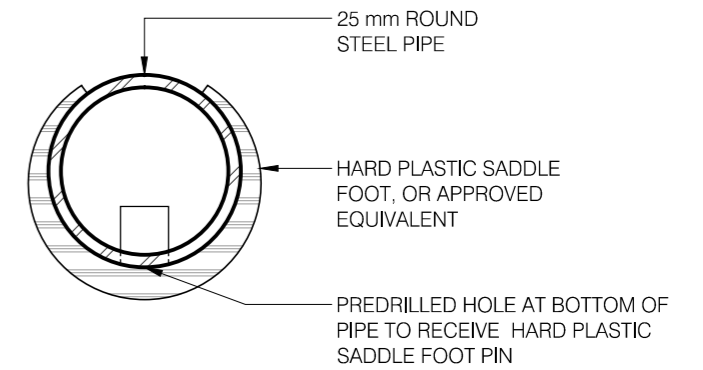

B SECTION DETAIL
1:1 SCALE

NOTE: REFER TO DRAWING I-2 FOR OVERALL FURNITURE DIMENSIONS FOR SMALL, MEDIUM AND LARGE UNITS.

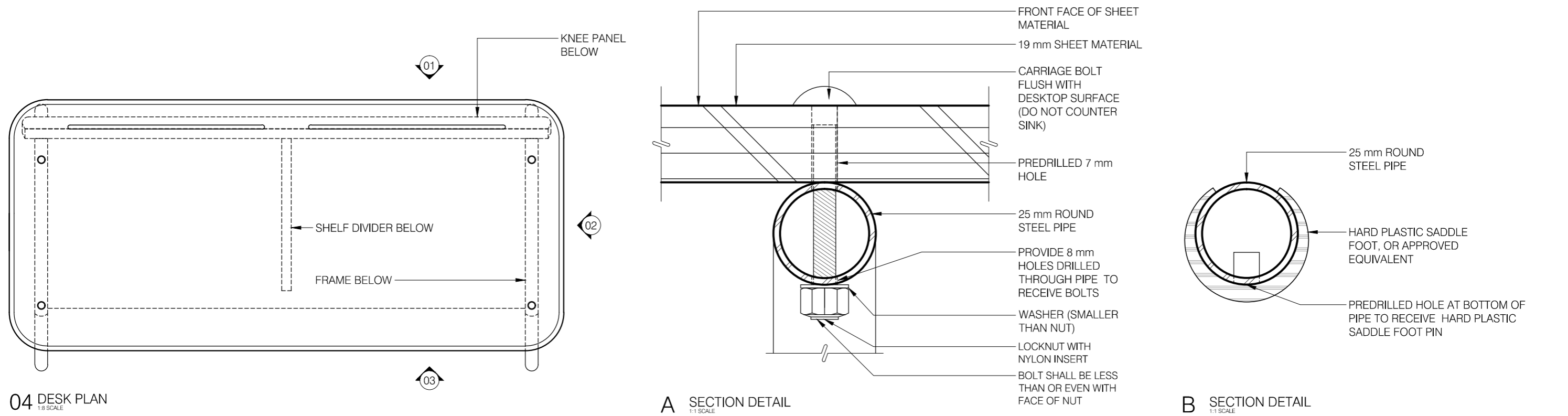
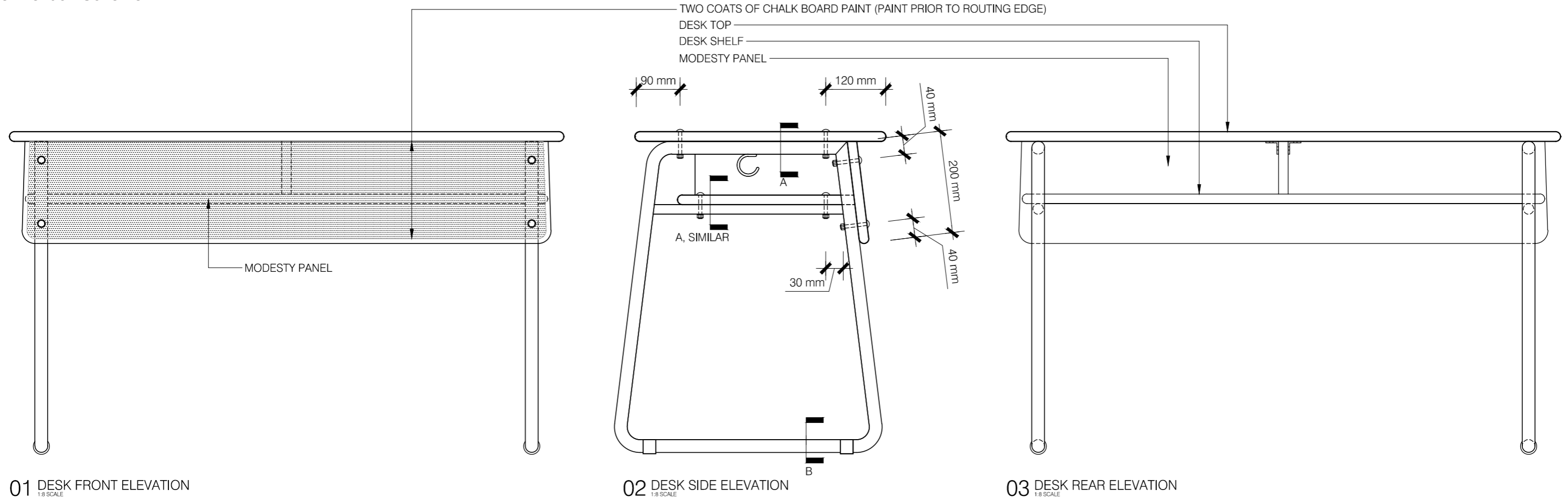

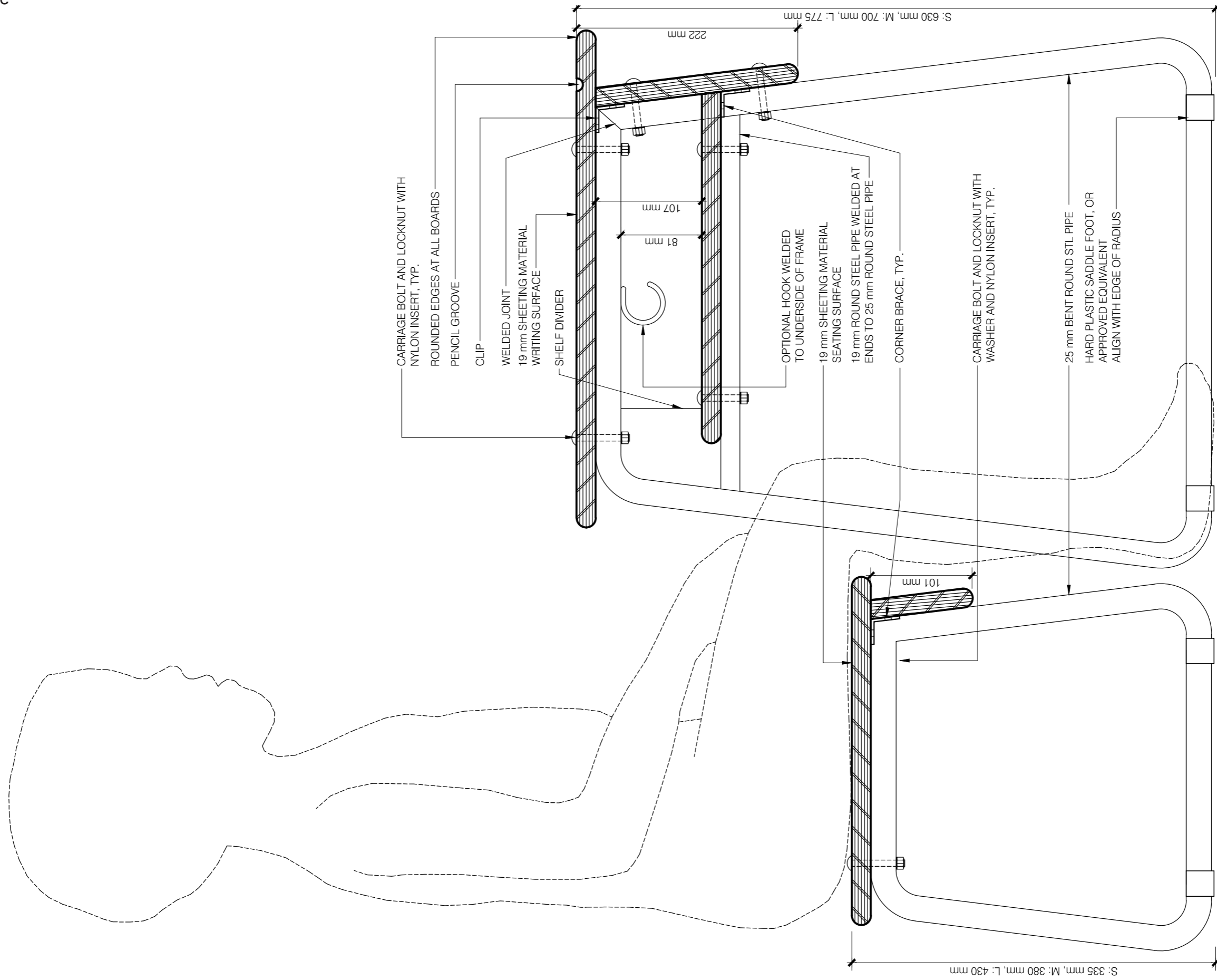

01 BENCH AND DOUBLE DESK SECTION
1:4 SCALE

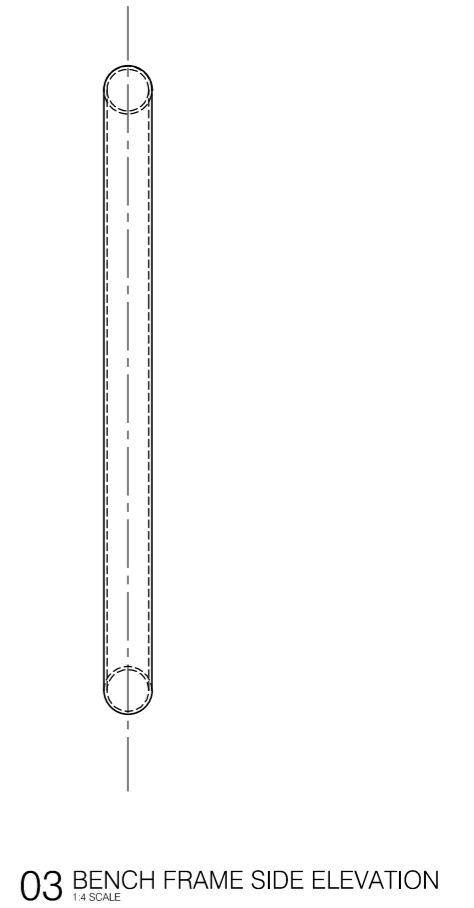
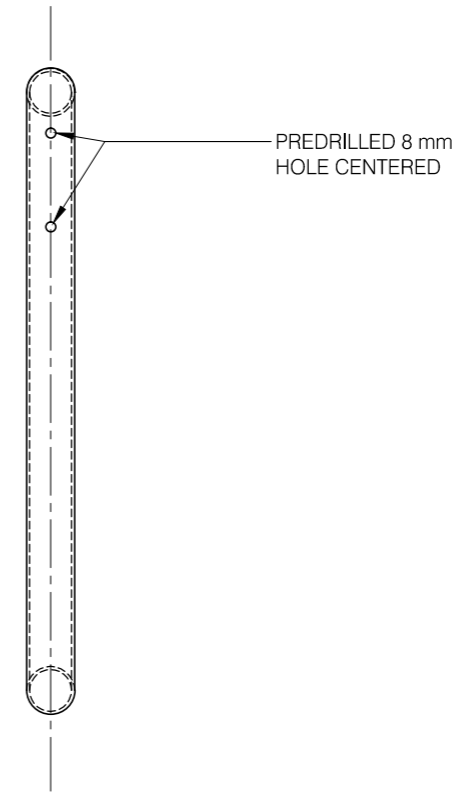
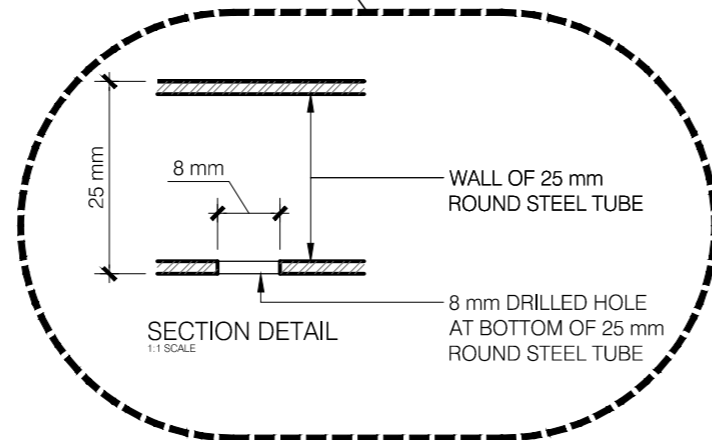
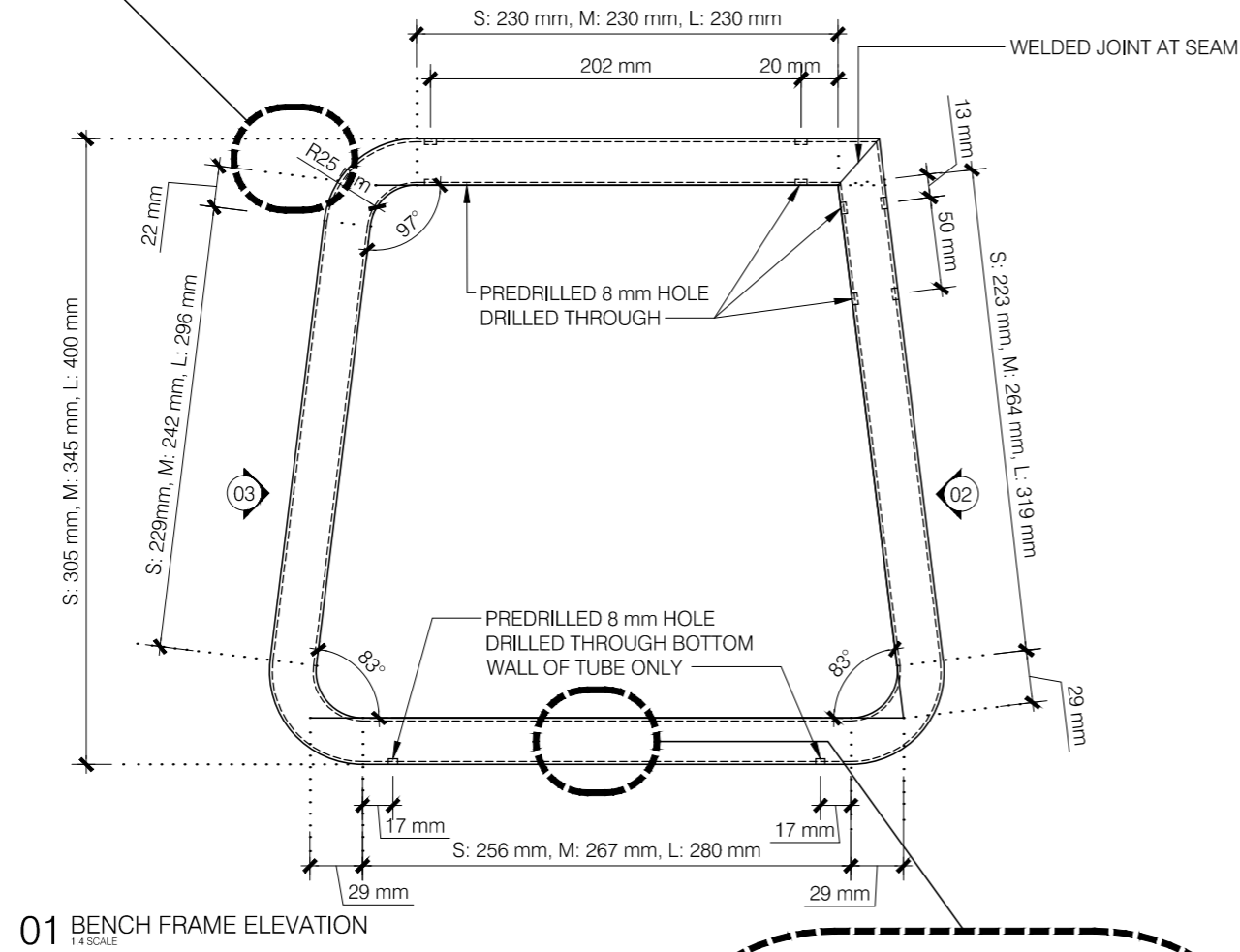
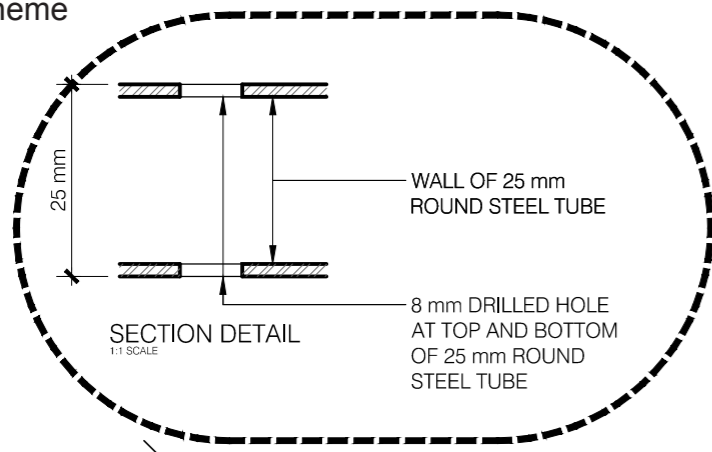

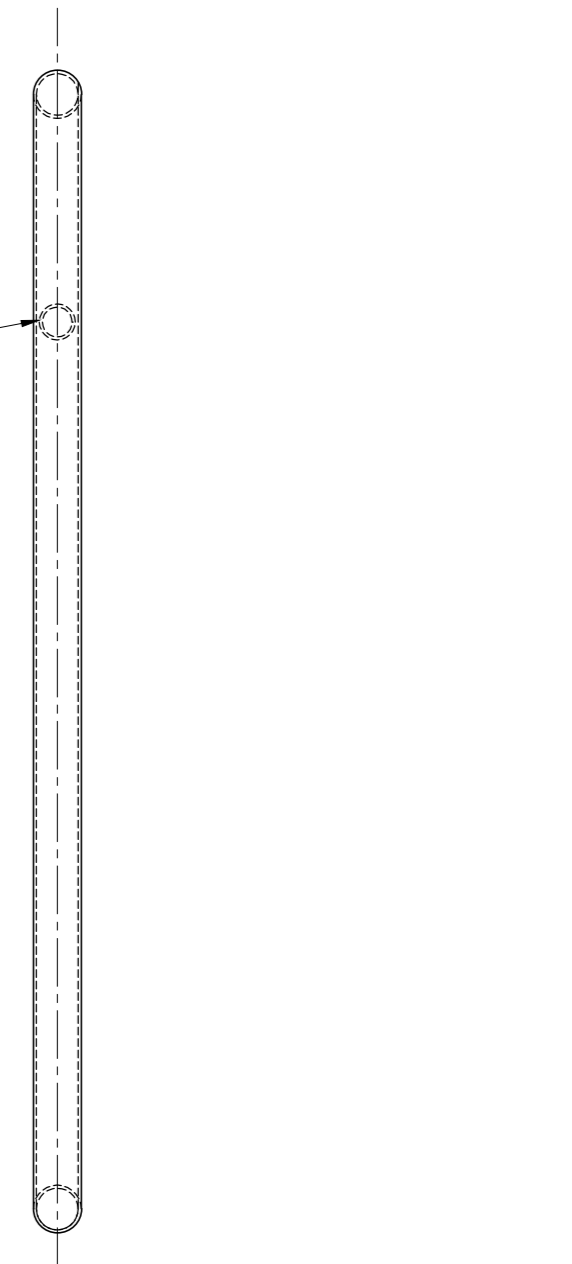
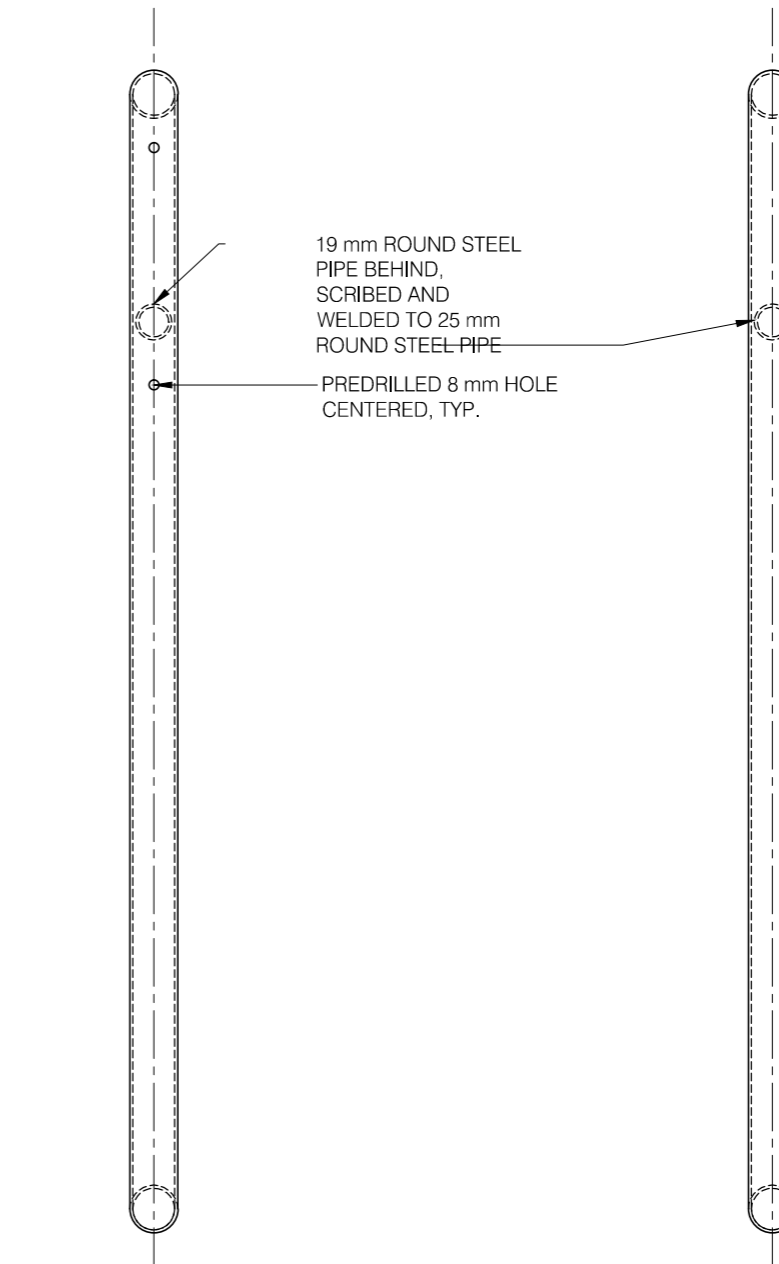
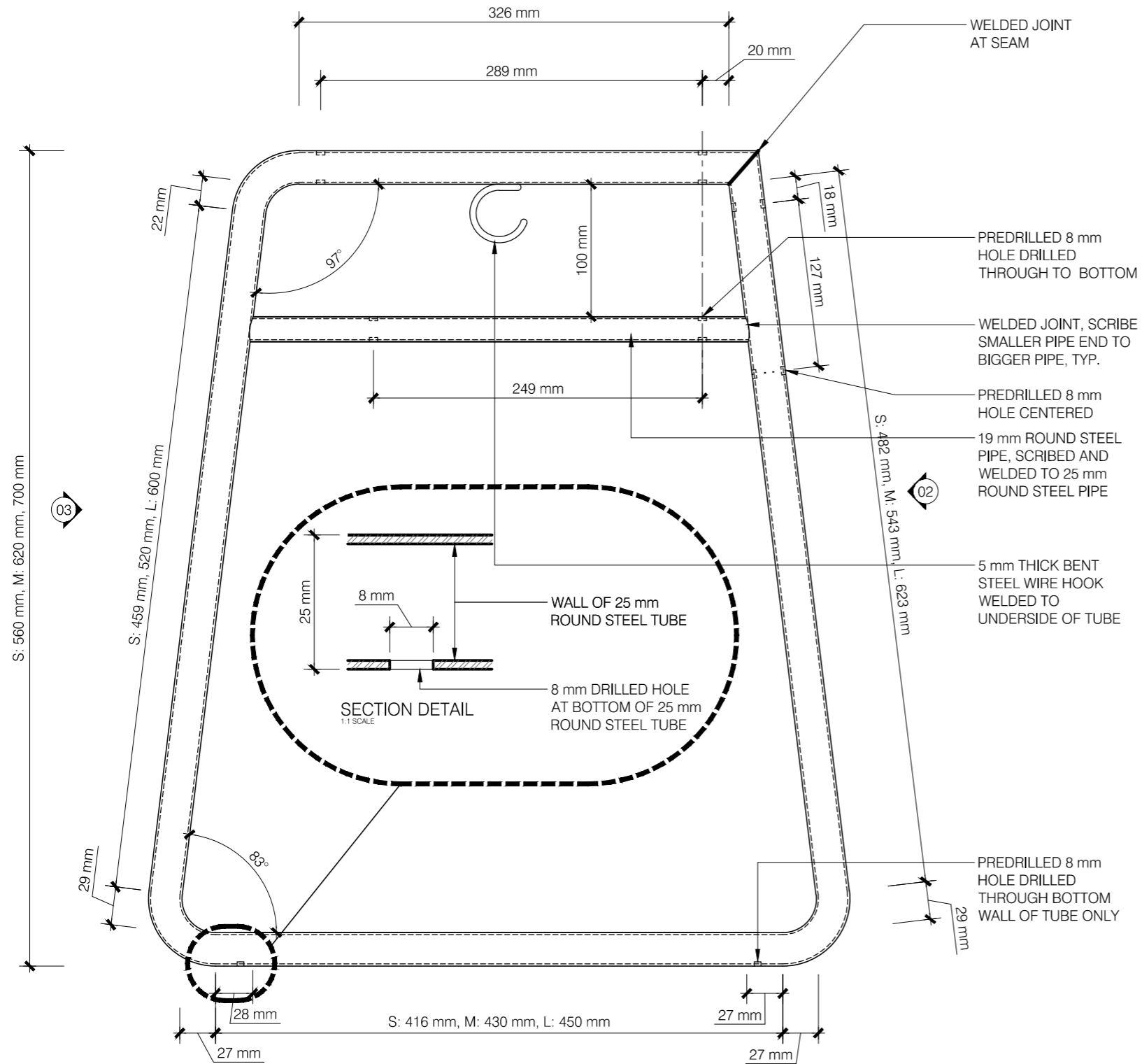

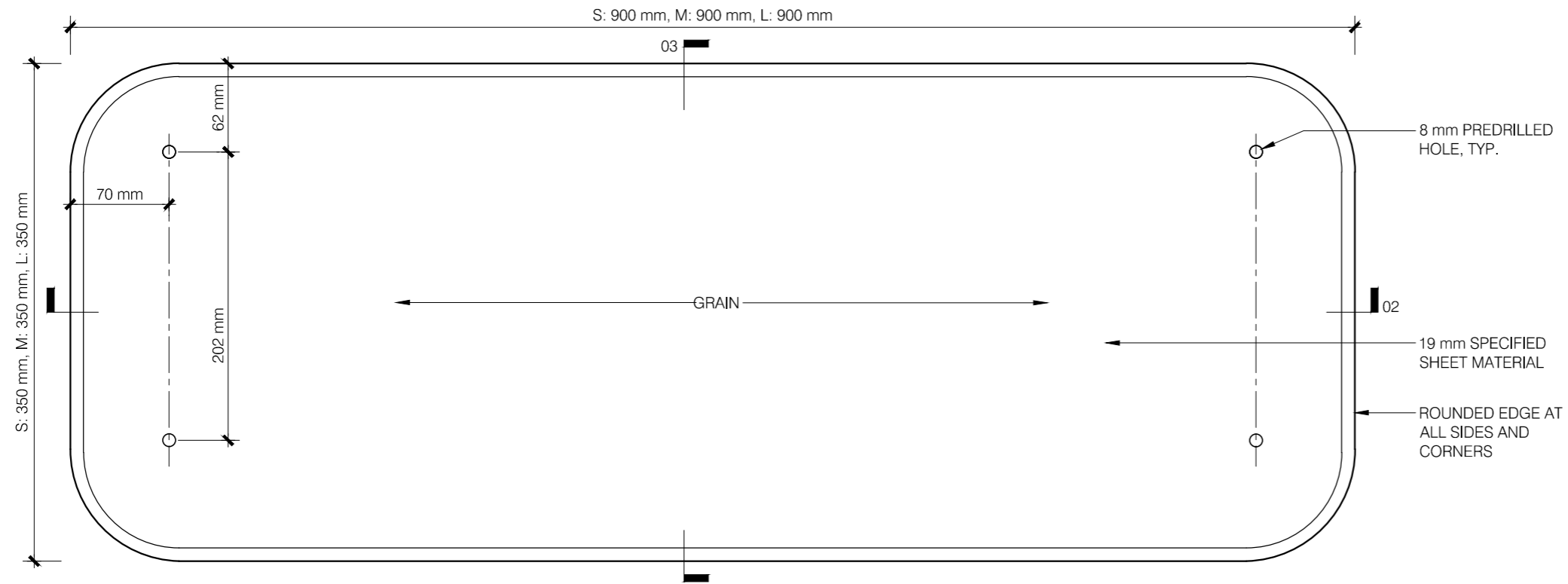

01 BENCH SEAT PLAN
1:4 SCALE

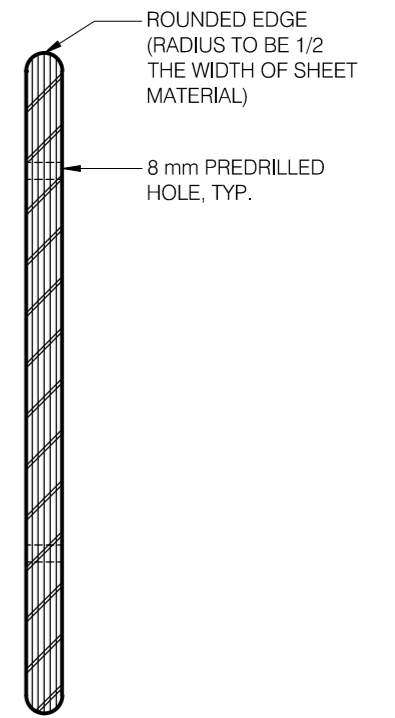

03 BENCH SEAT SECTION
1:4 SCALE



02 BENCH SEAT SECTION
1:4 SCALE

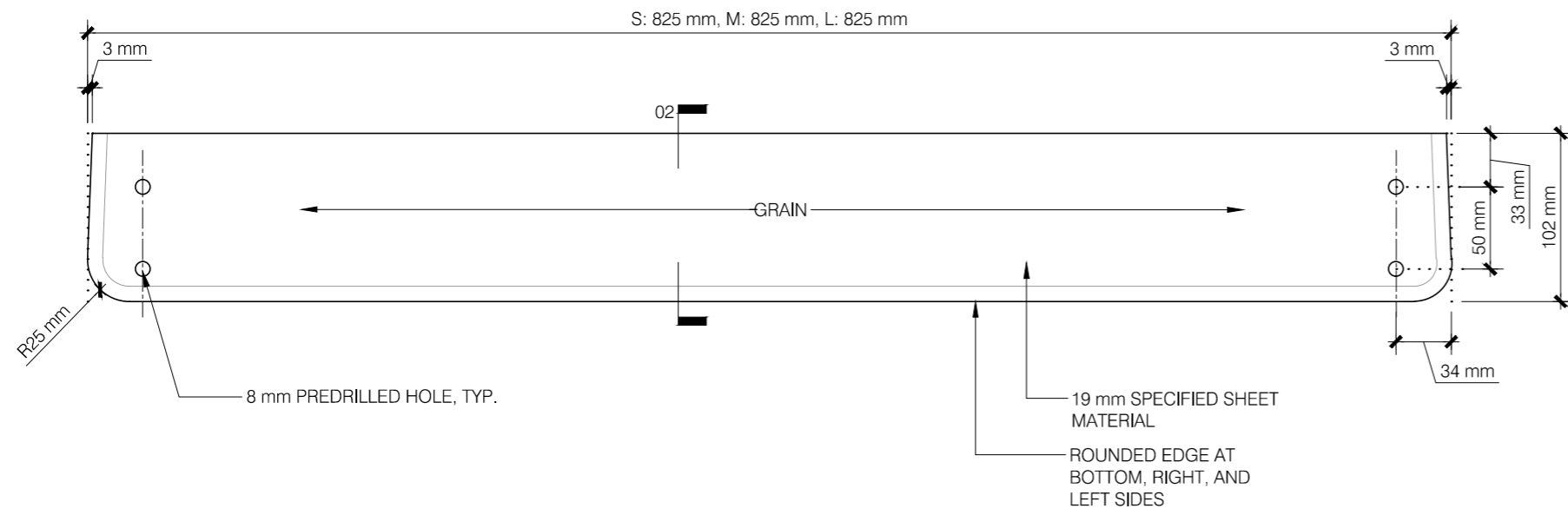

01 BENCH KNEE PANEL ELEVATION
1/4 SCALE

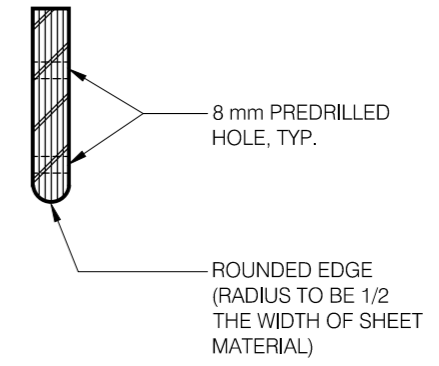

02 BENCH KNEE PANEL SECTION
1/4 SCALE

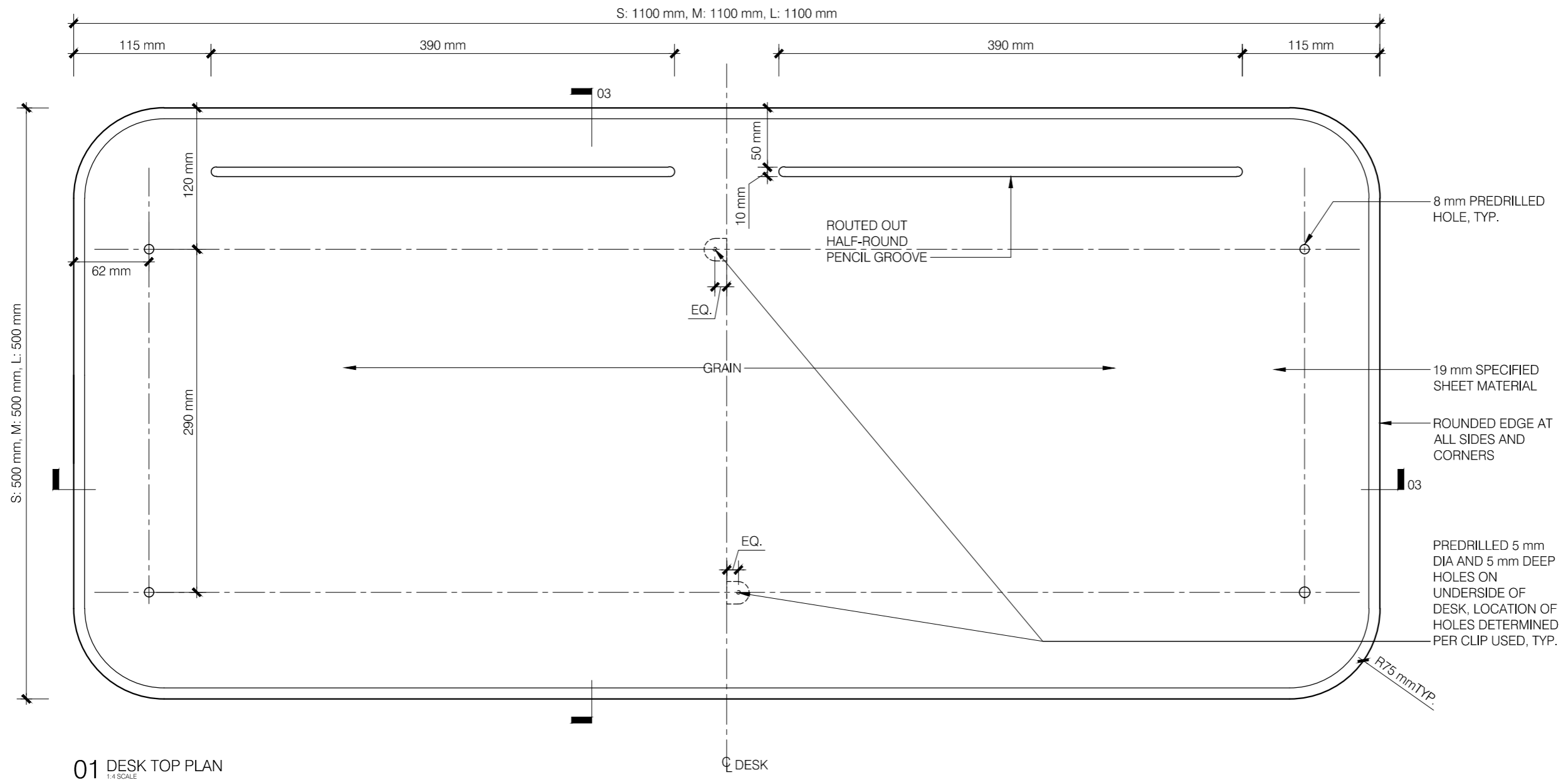

01 DESK TOP PLAN
1:4 SCALE

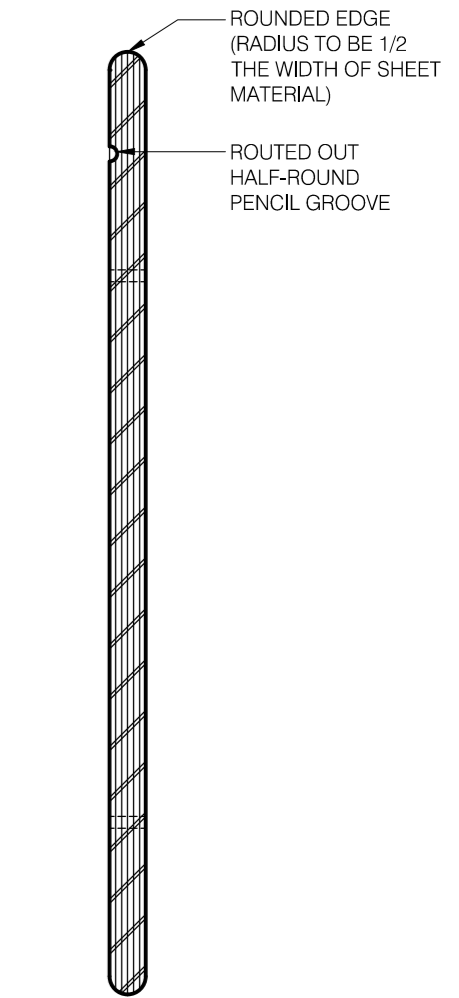

03 DESK TOP SECTION
1:4 SCALE

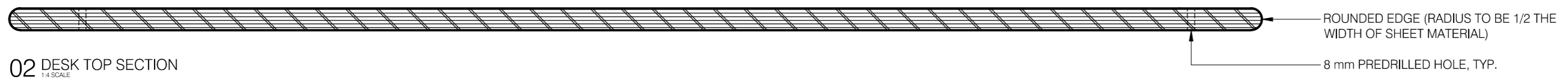

02 DESK TOP SECTION
1:4 SCALE

Scale
1:4
Date
26 August 2015

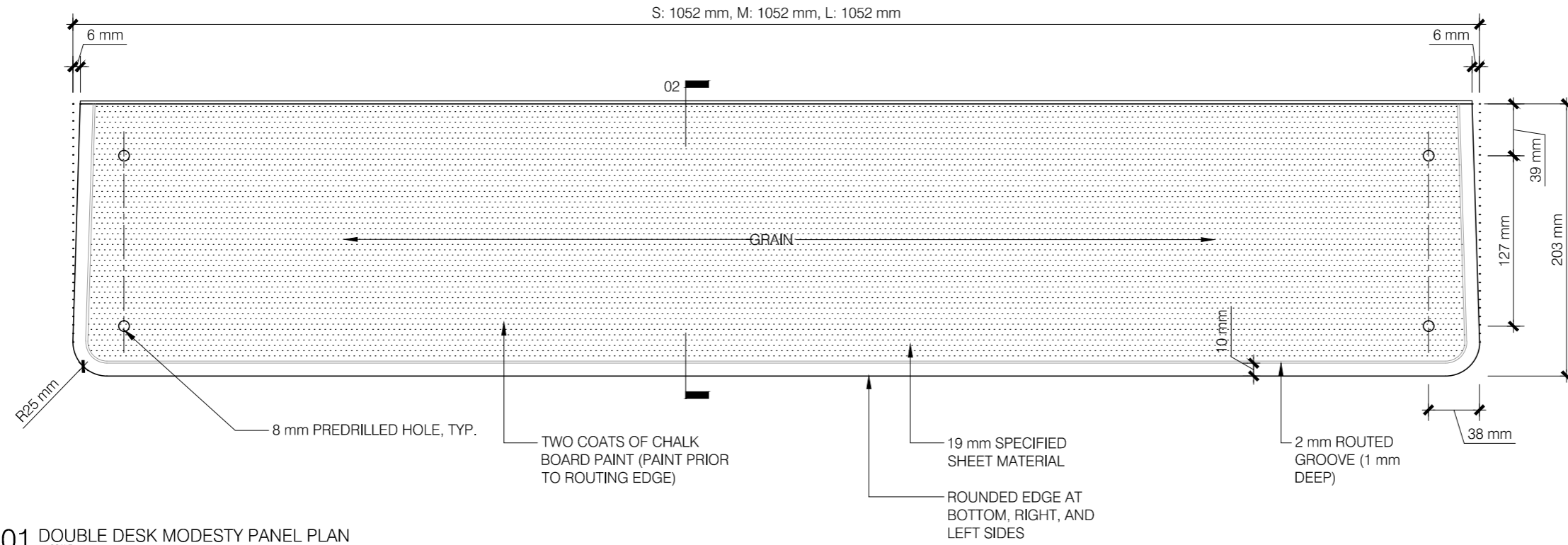

01 DOUBLE DESK MODESTY PANEL PLAN
1:4 SCALE

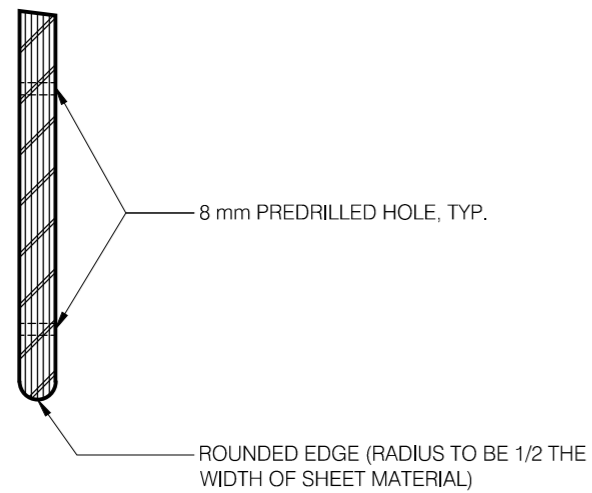

02 DOUBLE DESK MODESTY PANEL SECTION
1:4 SCALE

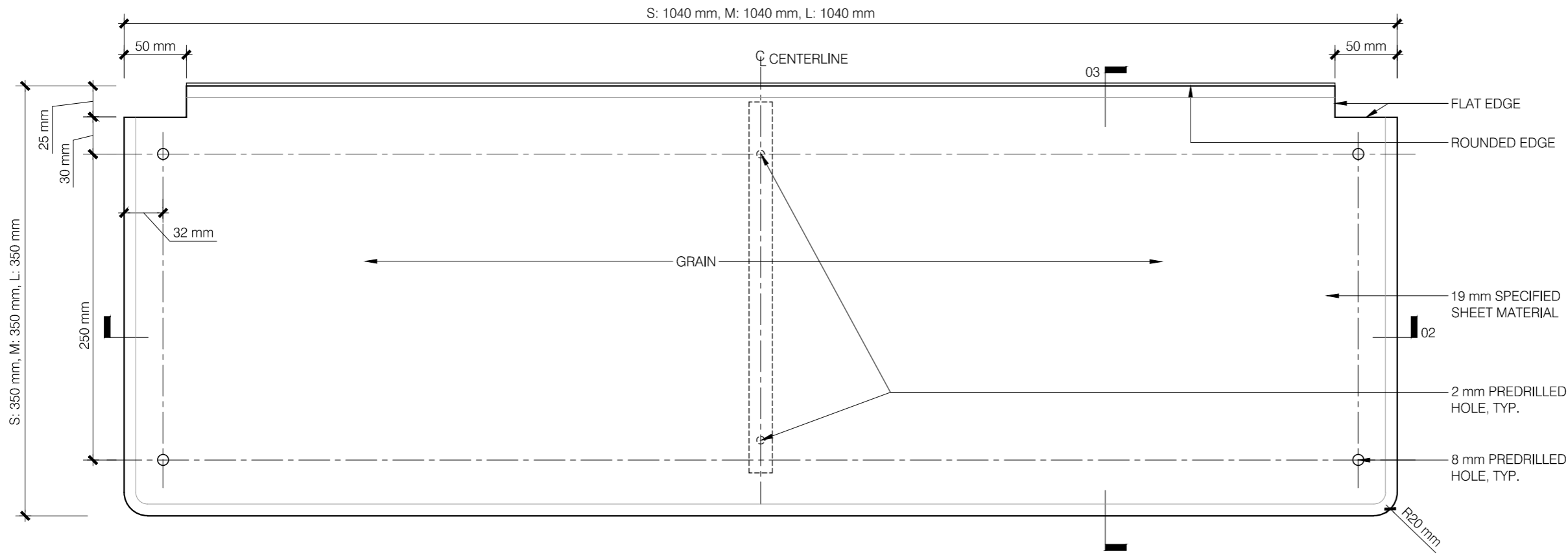

01 SHELF PLAN
1:4 SCALE

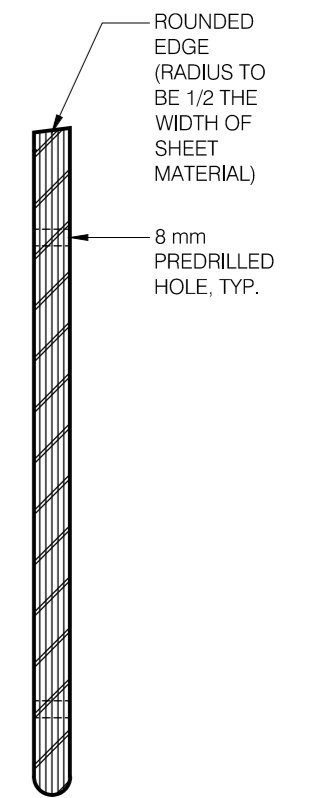

03 SHELF TOP SECTION
1:4 SCALE

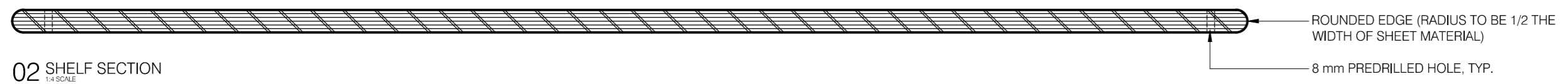

02 SHELF SECTION
1:4 SCALE

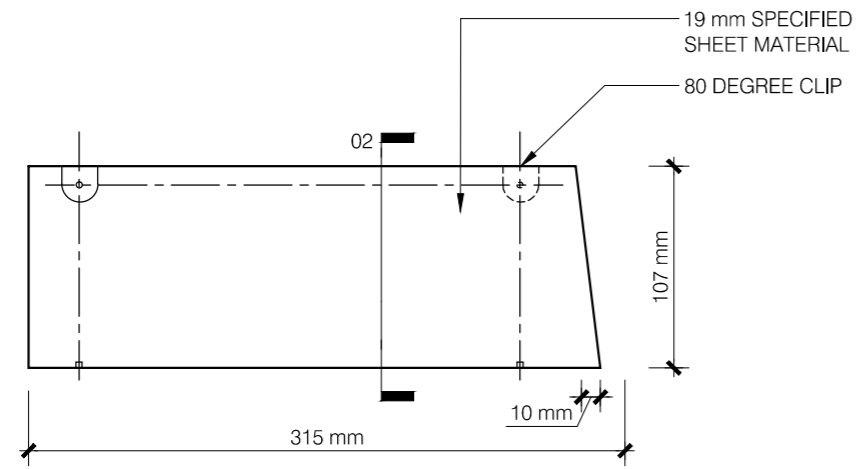

01 SHELF DIVIDER ELEVATION
1:4 SCALE

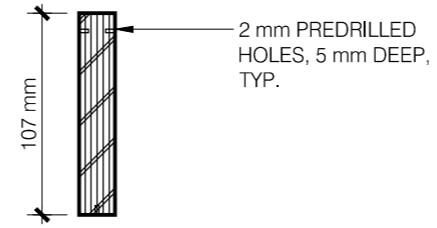

02 SHELF DIVIDER SECTION
1:4 SCALE

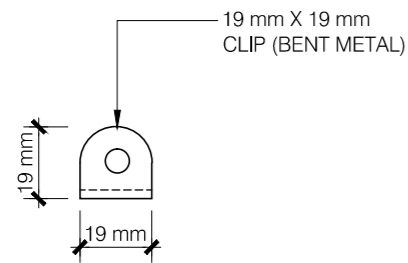

03 90 DEGREE CLIP FRONT ELEVATION
1:2 SCALE

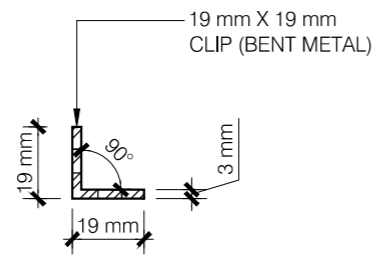

04 90 DEGREE CLIP SECTION
1:2 SCALE

[http://www.grainger.com/product/AMERICAN-GARAGE-DOOR-Carriage-Bolt-5MVD4?s_pp=false&picUrl=//static.grainger.com/rp/s/is/image/Grainger/3YHA9_AW99?smthumb\\$](http://www.grainger.com/product/AMERICAN-GARAGE-DOOR-Carriage-Bolt-5MVD4?s_pp=false&picUrl=//static.grainger.com/rp/s/is/image/Grainger/3YHA9_AW99?smthumb$)



[http://www.grainger.com/product/Steel-SAE-Washer-WP119355/_/N-/Nlt-flat+washer+zinc+plated?nlis=0&sst=subset&s_pp=false&picUrl=//static.grainger.com/rp/s/is/image/Grainger/29DJ14_AS01?smthumb\\$](http://www.grainger.com/product/Steel-SAE-Washer-WP119355/_/N-/Nlt-flat+washer+zinc+plated?nlis=0&sst=subset&s_pp=false&picUrl=//static.grainger.com/rp/s/is/image/Grainger/29DJ14_AS01?smthumb$)



[http://www.grainger.com/product/3HDU1?cm_sp=HIO-_-HIDP-_-BTM_V2V&cm_vc=IDPBVZ12&zoned=IDPBZ12\\$](http://www.grainger.com/product/3HDU1?cm_sp=HIO-_-HIDP-_-BTM_V2V&cm_vc=IDPBVZ12&zoned=IDPBZ12$)



<http://www.componentforce.co.uk/category/344/saddle-feet>



[http://www.grainger.com/product/GRAINGER-APPROVED-Wood-Screw-1KU70?s_pp=false&picUrl=//static.grainger.com/rp/s/is/image/Grainger/1KU70_AS02?smthumb\\$](http://www.grainger.com/product/GRAINGER-APPROVED-Wood-Screw-1KU70?s_pp=false&picUrl=//static.grainger.com/rp/s/is/image/Grainger/1KU70_AS02?smthumb$)





<http://www.amazon.com/Stainless-Design-Degree-Corner-Bracket/dp/B008X0FLU8>



HARDWARE REQUIRED FOR ASSEMBLY

REINVENTION DOUBLE BENCH	REINVENTION DOUBLE DESK
--------------------------	-------------------------

 X 8 CARRIAGE BOLT
M8 X 55 mm

 X 48 CARRIAGE BOLT
M8 X 35 mm

 X 8 M8 WASHER

 X 48 M8 WASHER

 X 8 M8 HEX
LOCKNUT WITH
NYLON INSERT

 X 48 M8 HEX
LOCKNUT WITH
NYLON INSERT

 X 4 SADDLE FOOT

 X 16 SADDLE FOOT

 X 16 14 mm WOOD
SCREW

 X 8 90° CORNER
BRACKET

ASSEMBLY / REPAIR KIT

TOOLS	SPARE PARTS (FOR ONE DOUBLE DESK/BENCH UNIT)
-------	--

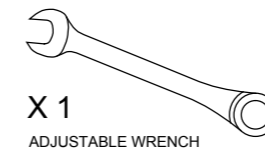
 X 1
ADJUSTABLE WRENCH

 X 16 CARRIAGE BOLT
M8 X 35 mm

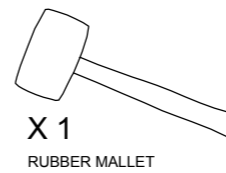
 X 1
RUBBER Mallet

 X 16 M8 HEX
LOCKNUT WITH
NYLON INSERT

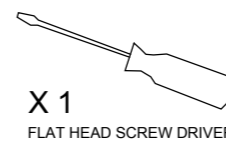
 X 1
FLAT HEAD SCREW DRIVER

 X 32 SADDLE FOOT

 X 8 14 mm WOOD
SCREW

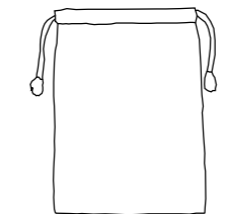

X 1
FABRIC DRAWSTRING BAG
FOR TOOLS AND SPARE
PARTS

NOTE: TWO ASSEMBLY/REPAIR KITS SHALL BE PROVIDED FOR EACH SCHOOL WITH ORDERS BETWEEN 1 AND 200 CHAIR/BENCH AND DESK UNITS. ONE ADDITIONAL KIT SHALL BE PROVIDED FOR EACH 1 TO 100 UNIT INCREMENT.

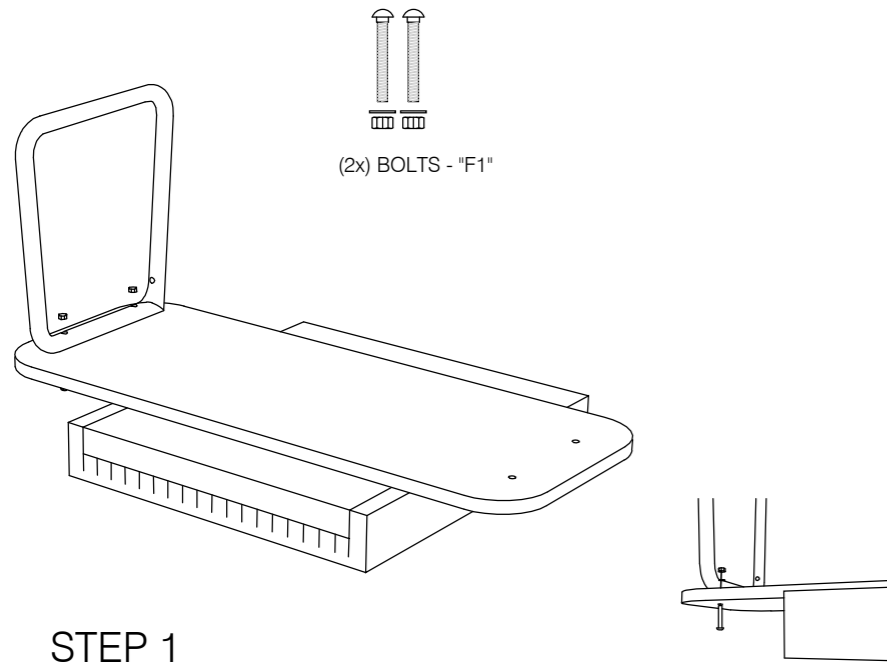

STEP 1

- SUPPORT THE BENCH TOP ON AN ELEVATED WORK SURFACE THAT IS COVERED WITH FABRIC OR ANOTHER SOFT MATERIAL
- FASTEN ONE OF THE STEEL LEGS TO THE BENCH TOP.
- TAP IN THE BOLTS SO THE HEAD IS FLAT TO THE WOOD AND TIGHTEN NUTS. BE CAREFUL NOT TO TIGHTEN TOO TIGHT TO AVOID BREAKING THE WOOD SURFACE.

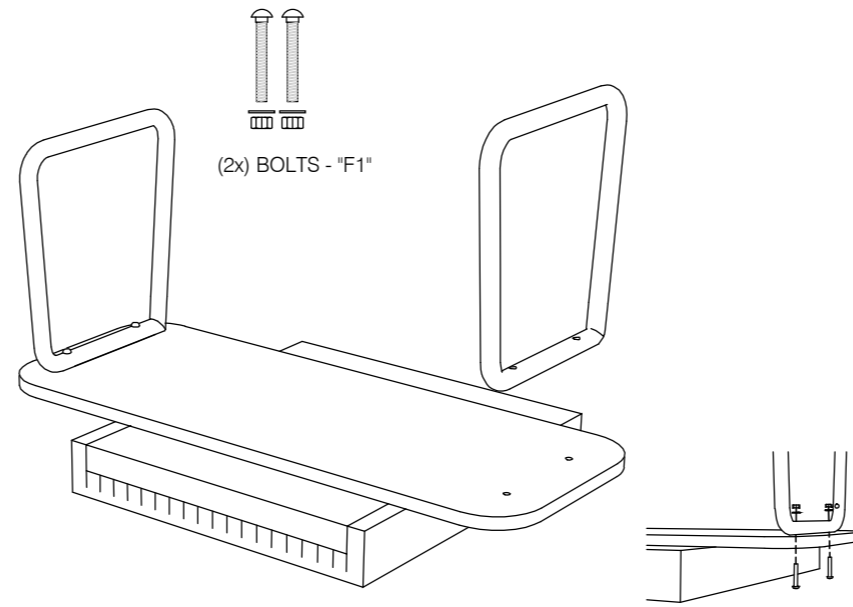

STEP 2

- SECURE THE SECOND LEG TO THE BENCH TOP
- MAINTAIN THE BENCH TOP PARALLEL TO THE WORK SURFACE AND THE LEGS AT A 90 DEGREE ANGLE. BE CAREFUL NOT TO TIGHTEN TOO TIGHT TO PREVENT BREAKING THE WOOD SURFACE.

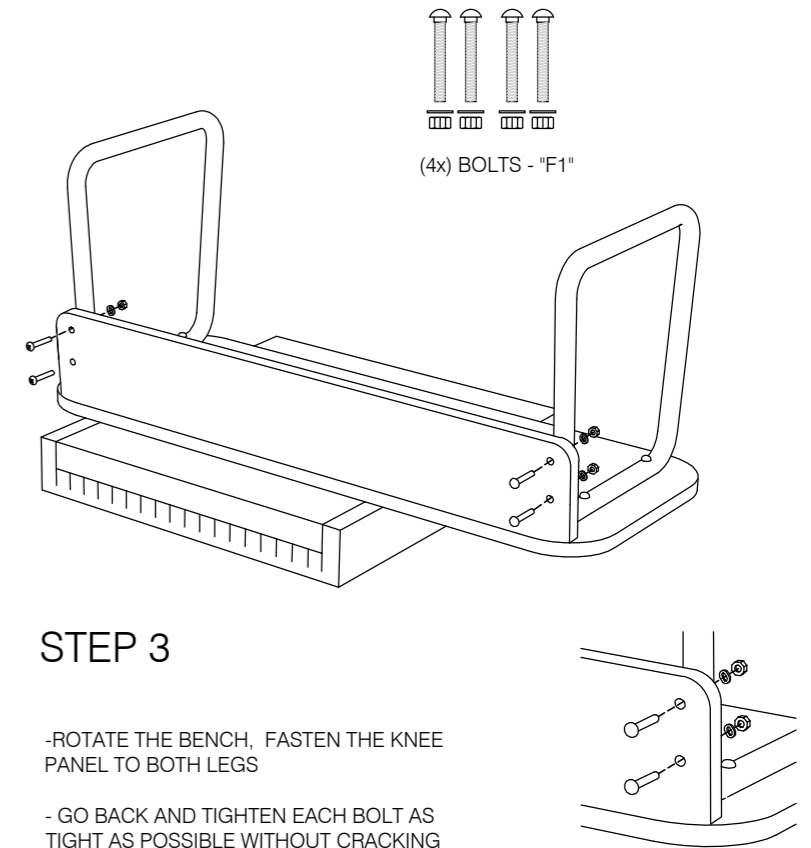

STEP 3

- ROTATE THE BENCH, FASTEN THE KNEE PANEL TO BOTH LEGS
- GO BACK AND TIGHTEN EACH BOLT AS TIGHT AS POSSIBLE WITHOUT CRACKING WOOD SURFACE

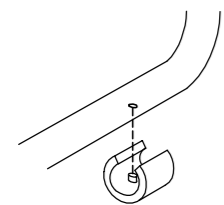

STEP 4

- ADD HARD PLASTIC SADDLE FOOT

COMPLETE

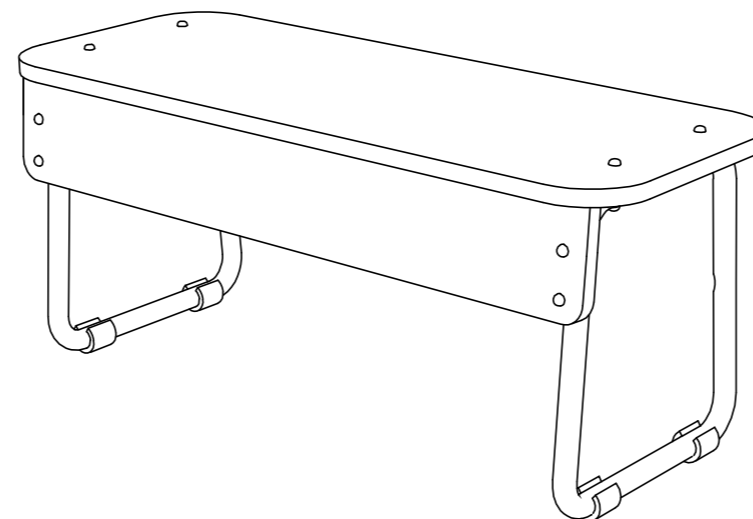

TOOLS REQUIRED:

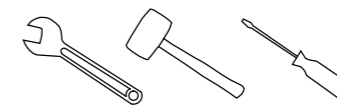

OPTIONAL

- ADD (2) HARD PLASTIC SADDLE FEET TO EACH FRAME

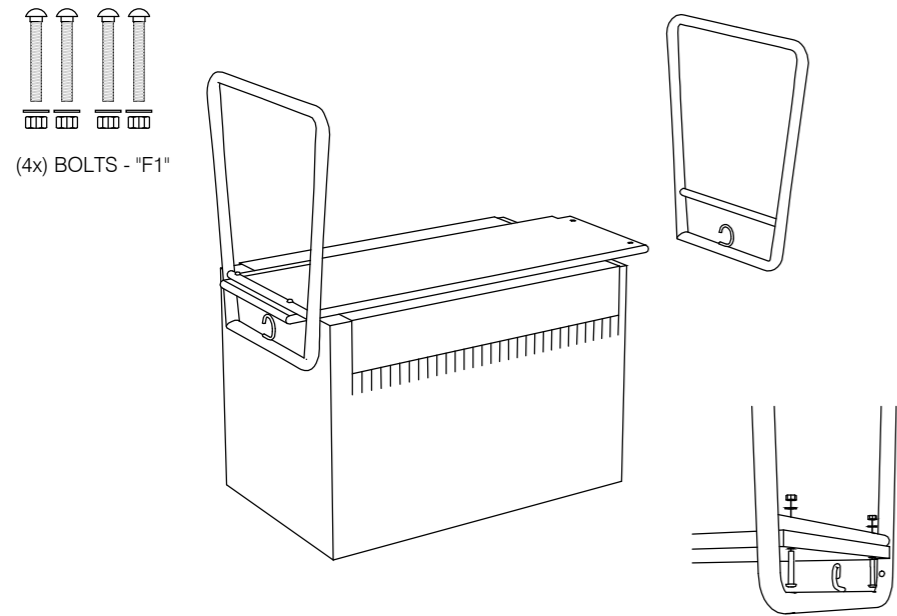

STEP 1

- LAY THE DESK SHELF ON AN ELEVATED SURFACE THAT IS COVERED WITH FABRIC OR ANOTHER SOFT MATERIAL.
- FASTEN EACH OF THE STEEL LEGS TO THE DESK SHELF.
- ENSURE THAT THEY ARE ORIENTED IN THE SAME DIRECTION. TAP IN THE BOLTS SO THE HEAD IS FLAT TO THE WOOD AND TIGHTEN NUTS. BE CAREFUL NOT TO TIGHTEN TOO TIGHT TO AVOID BREAKING THE WOOD SURFACE.

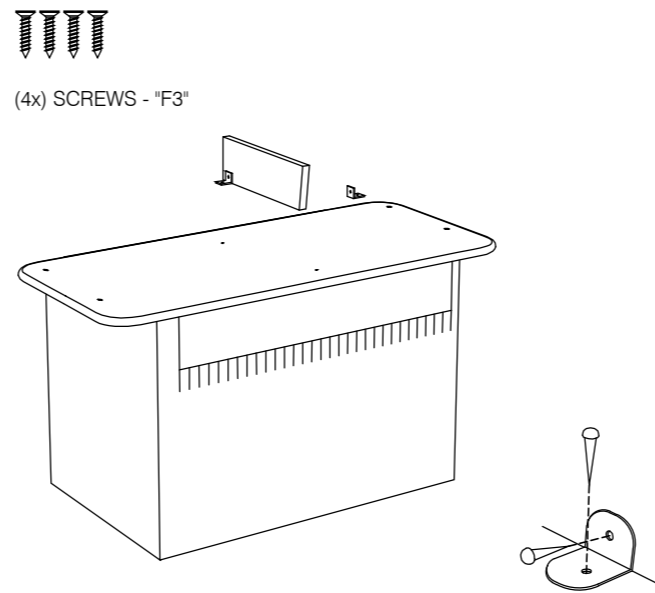

STEP 2

- FASTEN THE SHELF DIVIDER TO THE UNDERSIDE OF THE DESKTOP
- USE (2) ANGLES, AND SCREW THEM INTO PREDRILLED HOLES IN WOOD

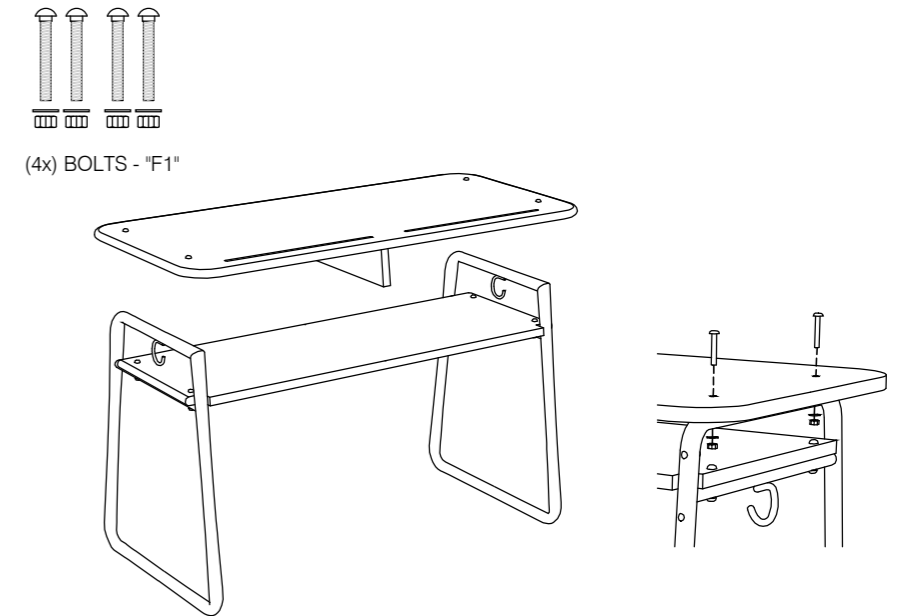

STEP 3

- LAY THE DESKTOP AND SHELF DIVIDER ON TOP OF THE STEEL LEGS
- FASTEN EACH OF THE STEEL LEGS TO THE DESKTOP

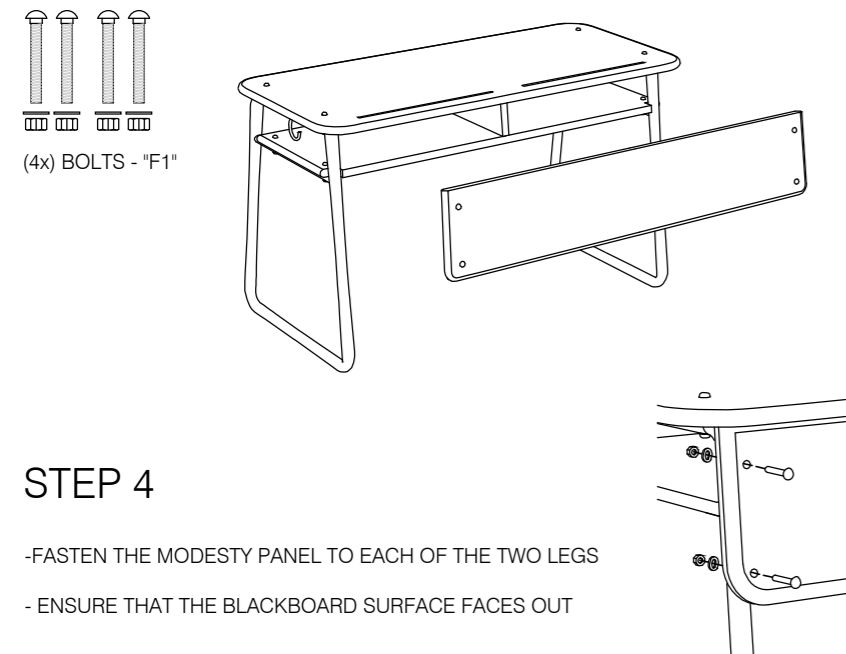

STEP 4

- FASTEN THE MODESTY PANEL TO EACH OF THE TWO LEGS
- ENSURE THAT THE BLACKBOARD SURFACE FACES OUT

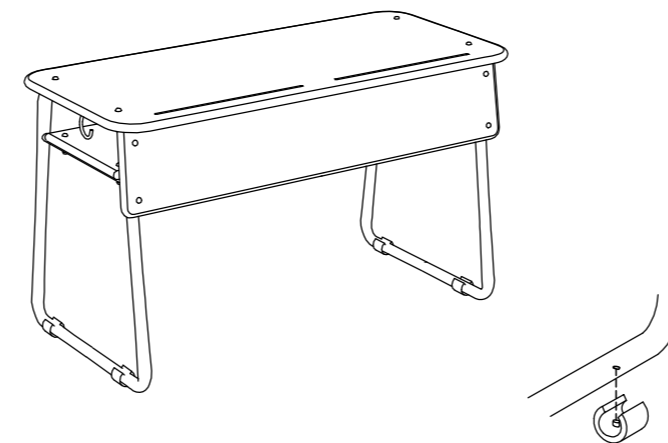

STEP 5

- ADD HARD PLASTIC SADDLE FOOT TO EACH FRAME
- GO BACK AND TIGHTEN EACH BOLT AS TIGHT AS POSSIBLE WITHOUT CRACKING WOOD SURFACE

COMPLETE

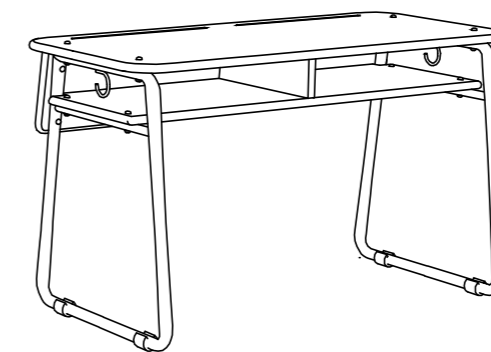

TOOLS REQUIRED:

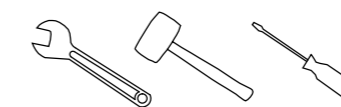



CHAIR SEAT / LEG CONNECTION



SHELF DIVIDER CLIP CONNECTION WITH DESK TOP



DESK / SHELF CONNECTION SHOWING BAG HOOK



FRONT DESK CONNECTION SHOWING CHALKBOARD EDGE
AFTER ROUTING AND BOLT HEADS TO SURFACE



OBLIQUE



SIDE ELEVATION



FRONT ELEVATION



BACK ELEVATION